



ALPINE SANITATION & SUPPLIES LTD.
24 Ronson Drive, Unit 16, Etobicoke, Ontario M9W 1B4
Bus: (416)-744-2120 Fax: (416)-249-1859 Toll Free: 1-800 465-6198

501LT

Undercounter Low Temperature Dishwashing Machine

***The 501LT is compact, cost efficient,
reliable, easy to maintain and service...
Saves time and money!***

Fully automatic wash/rinse cycle processes
a rack of wares in 140 seconds
21 racks an hour!

Easy to operate: On to fill, Off to drain.

Pumped drain permits use of drain connections
up to 4 feet [1220mm] above the floor.

Upper and lower wash/rinse arms produce
sparkling clean ware every time.

Thermostatically controlled wash tank heater
maintains water at the required temperature.

Exclusive vent design permits venting of
condensation.

Heavy-duty stainless steel construction.

16" [406mm] door opening accommodates larger
wares, *including trays!*

Sanitizer pump and detergent pump standard.

Complete with two 20" x 20" [508mm x 508mm]
racks (peg rack and flat rack).

One year parts and labor warranty.

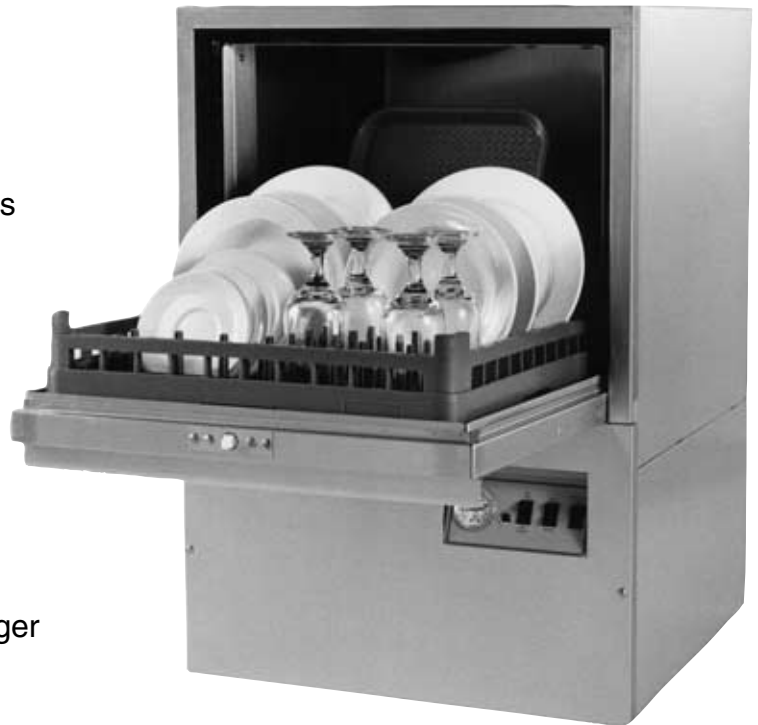

* Shown with optional
top and side panels

Moyer Diebel
P.O. Box 4183
Winston-Salem, NC 27115
336/661-1992
Fax: 336/661-1979
www.moyerusa.com

Moyer Diebel Ltd.
2674 North Service Rd.
Jordan Station, Ontario
Canada L0R 1S0
905/562-4195
Fax: 905/562-4618
sales@moyerdiebellimited.com



501LT

Low Temperature
Undercounter Dishwashing Machine

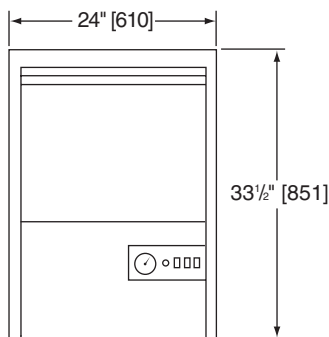

Front View

Dimensions shown in
inches and millimeters

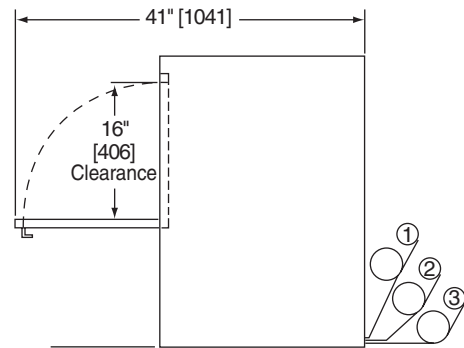

Side View

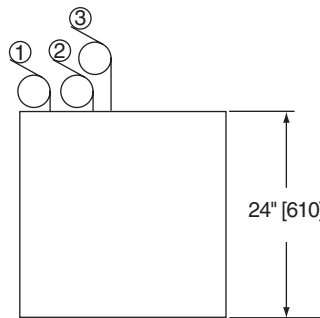

Plan View



Quick Facts

Capacity

Racks per hr. 21

Motor horsepower

Wash 0.5

Water Consumption

Per hr. (max. use) 37 US gal;
147 liters;
31.5 imp. gal

Per rack 1.8 US gal;
7 liters;
1.5 imp. US gal

Temperatures °F/C

Wash (minimum)* 140/60

Rinse 140/60

Heating

Tank heat, electric (Kw) 0.75

Time cycle in seconds

Wash 80

Rinse 23

Drain/fill 37

* Supply water temperature 140°F/60°C Min.

Utilities

1 Electrical connection:
115/60/1, 13 amp draw, to be fused at 15 amp.
4ft. plug-in cord supplied.

2 Water connection:
140°F/60°C Min., 6 ft. long, 1/2" I.D. flexible fill hose with
3/4" hose connector
Flow pressure: 25-95 psi (173-656 kPa)

3 Drain connection:
6 ft. long, 5/8" I.D. flexible hose
Max drain flow: 8 US gpm, 30 lpm, 7 imp. gpm

Warning:

Plumbing and electrical connections should be made by qualified personnel who will observe all the applicable plumbing, sanitary and safety codes.

Due to an ongoing value analysis program at Moyer Diebel, specifications in this catalog are subject to change without notice.

Optional Accessories

- Kit 504 - top and side panel
- Kit 505 - top panel
- Kit 506 - left side panel
- Kit 507 - right side panel
- Kit 508 - rinse aid pump kit
- 17RS - 17" rack storage stand
- CST - Combination sink/table
- 6T - 6" stand

	Uncrated	Crated
Height*	33-1/2" [851]	9-1/2" [1003]
Width	24" [610]	25" [635]
Depth	24" [610]	25-1/2" [647]
Ship Wt. lbs/kg	153/70	173/79

* Front leveling feet provided.